

# SWINGSET™ EDI ELECTRIC DISTRIBUTOR

Installation and Operation Manual

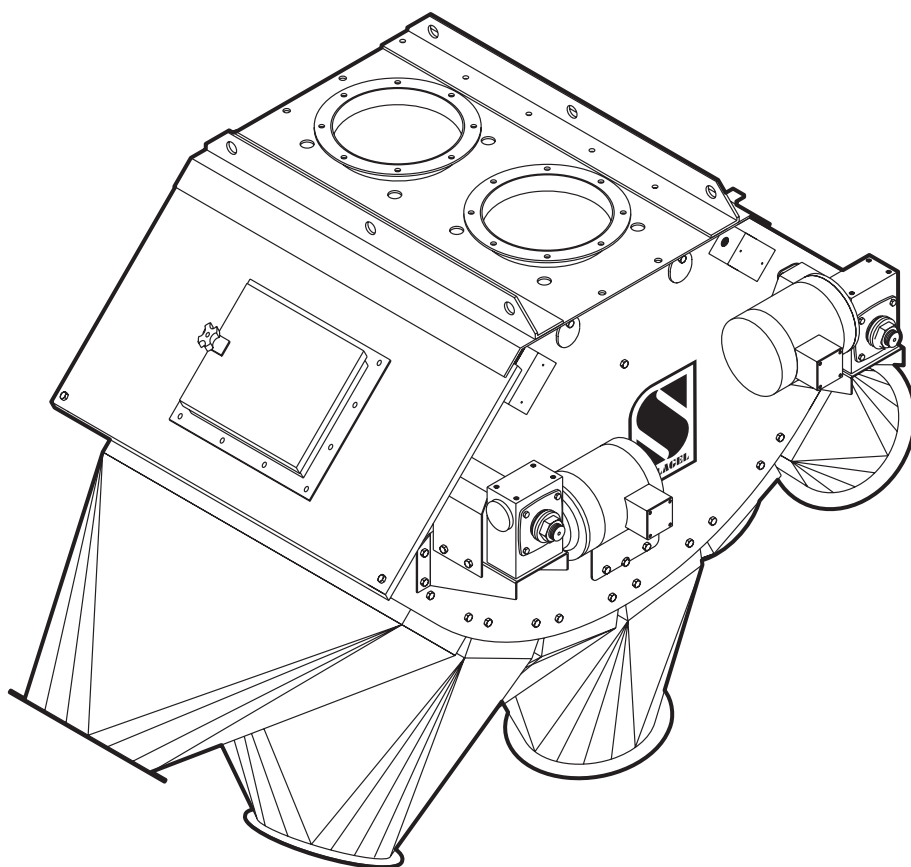

## SCHLAGEL

*Manufacturers of Innovative Materials Handling Equipment since 1957.*

491 North Emerson Street \* Cambridge MN 55008-1316 U.S.A.  
Toll Free (800) 328-8002      FAX (763) 689-5310  
Local / International (763) 689-5991      EMAIL sales@schlagel.com  
**www.schlagel.com**

# TABLE OF CONTENTS

---

## SECTION 1 - GENERAL

|       |   |       |                          |
|-------|---|-------|--------------------------|
| Pages | 1 | ..... | Introduction             |
|       | 1 | ..... | Use of Manual            |
|       | 2 | ..... | Information Service      |
|       | 2 | ..... | Uncrating and Inspection |
|       | 2 | ..... | Safety Code              |

## SECTION 2 - ASSEMBLY AND INSTALLATION

|       |     |       |                              |
|-------|-----|-------|------------------------------|
| Pages | 3   | ..... | Installation                 |
|       | 4   | ..... | Spout Removal & Installation |
|       | 4   | ..... | Inner Flex Removal           |
|       | 5-7 | ..... | Parts List and Drawings      |

## SECTION 3 - OPERATION AND MAINTENANCE

|       |    |       |                              |
|-------|----|-------|------------------------------|
| Pages | 8  | ..... | Sensor & Chain Block Detail  |
|       | 9  | ..... | Gear Reducer                 |
|       | 9  | ..... | Operation & Trouble Shooting |
|       | 10 | ..... | Trouble Shooting             |

## INTRODUCTION

---

This distributor has been designed to give you many years of faithful service. To obtain all of the benefits built in to it, the following instructions should be read and adhered to as closely as possible during installation. These instructions are suggestions to help the installer determine the best way to mount the unit.

## USE OF MANUAL

---

This manual provides installation, operation, service recommendations and replacement parts identification for Schlagel SwingSet EDI Distributors.

Each section of the manual is fully illustrated for fast, accurate reference. It is highly recommended that this manual be read thoroughly by those who are responsible for the installation, operation and maintenance of this distributor. Refer to the Table of Contents, on this page for the location of specific information.

As new information and equipment become available, service and parts bulletins will be issued by Schlagel, Inc. So that they will be readily available for reference, all bulletins should be inserted with this manual. **For wiring or electrical information please refer to the EDI Control Installation Manual.** This manual covers standard distributor equipment only. For any items or special equipment not covered in this manual, please consult our service department for recommendations or instructions regarding this equipment.

**INFORMATION SERVICE**

Enclosed with your distributor shipment is our packing list that details all items on your order. This packing list should be saved for future reference. The invoice number shown on this document is the same as the serial number shown on your distributors I.D. tag. If you ever need to call the factory for parts or service it is very helpful to have this serial number available. Please record the information below now and save this booklet for future reference.

Date of Purchase: \_\_\_\_\_

Purchased from: \_\_\_\_\_

Installed by: \_\_\_\_\_ Date: \_\_\_\_\_

Serial Number: \_\_\_\_\_

Model: \_\_\_\_\_

Email or Call: Schlager, Inc.  
 491 North Emerson Street  
 Cambridge, MN 55008  
 (763) 689-5991 or 1-800-328-8002  
 sales@schlager.com

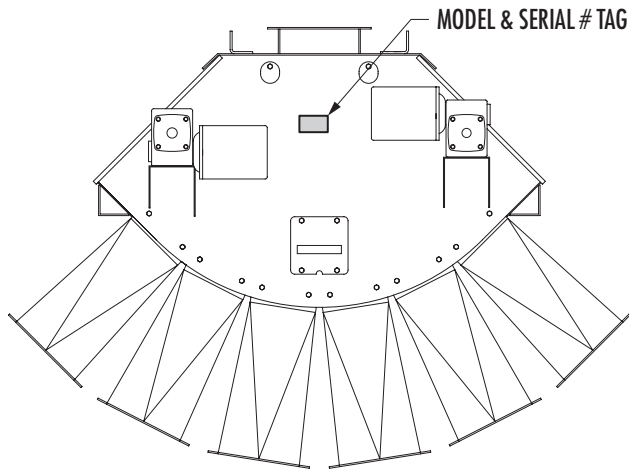

**UNCRATING AND INSPECTION**

Your distributor has been carefully checked and operated before shipment from our factory. In the event that any parts are missing or damaged, please notify us immediately and also have the delivering carrier note this is on the Bill of Lading.

**IMPORTANT**

*All claims for shipping damages must be noted by the consignee at the time of delivery and filed with the transportation company.*

**SAFETY CODE**

⚠ **WARNING** ⚠

The icon shown below was proposed as a safety alert symbol by the Farm and Industrial Equipment Institute (FIEI) and approved by the American Society of Automotive Engineers (ASAE) and others for the purpose of calling attention to safety precautions which if not heeded might lead to bodily injury.

*Please read instructions carefully and follow the instructions exactly wherever this symbol appears in the manual.*



**LOOK FOR THIS SAFETY LABEL**

⚠ **WARNING** ⚠

**ROTATING SPOUT CAN CAUSE SEVERE INJURY**

LOCK OUT  
POWER BEFORE  
OPENING DOOR

⚠ **DANGER** ⚠

**FALLING INTO TURNHEAD OUTLET WILL CAUSE SEVERE INJURY OR DEATH**

FOLLOW CONFINED  
SPACE ENTRY  
PROCEDURES

⚠ **WARNING** ⚠

**EXPOSED BELT CHAIN & MOVING PARTS CAN CAUSE SEVERE INJURY**

LOCK OUT  
POWER BEFORE  
REMOVING GUARD

### INSTALLATION

- When making a decision how to mount the distributor, keep in mind it is very important to provide access to the distributor inspection doors and electric drive mechanism for setup of the unit and for future maintenance requirements. We strongly recommend a service platform for access to these areas. There is a large formed angle with holes at each end corner of the unit that we recommend using to support the distributor. The best method is to run threaded rods down to these holes from your overhead structural platform. These rods are then used to level the distributor. Other methods of support are acceptable as long as they do not induce excessive stress to the body of the distributor.

**NOTE: The top plate of the distributor with the round inlet collar is not designed to support the distributor. If you connect the inlet transition(s) to the legs or conveyor before connecting the outbound spouting be very careful not to put excessive stress on the distributor body. Deflecting the top plate or twisting the body will cause the spouts to bind and lead to problems in operation.**

- Spout the outbound ducts, preferably using reversible elbows to obtain the desired angle on the spout. Connect the opposite duct of the distributor from the one previously spouted to limit stresses put on the base of the unit.
- Connect the inlet from the conveyor or leg, but do not apply extreme pressure to the inlet collar.

**NOTE -** The inlet should be connected only after the spouting has been run to prevent bowing or twisting of the inlet plate. If this happens the spout may not swing or seat correctly.

We realize that in actual field assembly the first step is frequently connecting the inlet of the distributor to the leg and that this is generally the easiest way to establish the mounting location. If using this method be very careful when spouting the unit to not distort the body or the inlet collar. We receive many more complaints about inner spouts binding in the distributor when installed in this fashion.

#### ⚠ WARNING ⚠

Turn off and lock out power to the distributor motor to prevent anyone from operating the unit while you are servicing it.

- Assemble the motor to the gear reducer and refer to the *EDI Control Installation manual* for motor wiring.

#### ⚠ CAUTION ⚠

The distributor is not designed to support spouting.

There may have been a positive pressure fan provided with your SwingSet distributor. The purpose of the fan is to help prevent the moisture and dust from coming up the spouts and settling in the distributor. It is very important that this fan is installed so that the air flow is toward the inside of the distributor. Thus creating a positive pressure inside the distributor.

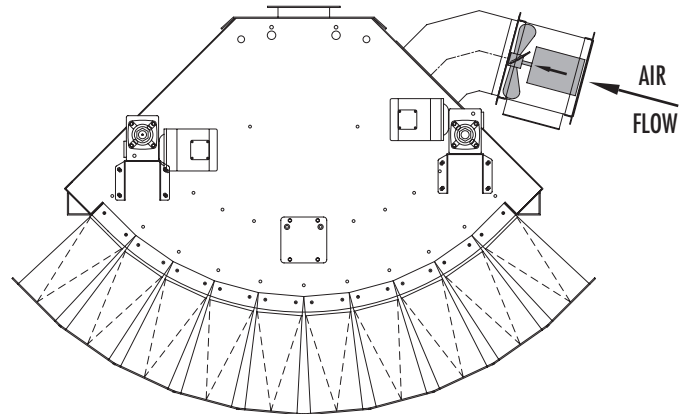

SWINGSET DISTRIBUTOR SHOWN WITH POSITIVE PRESSURE FAN

## INNER SPOUT REMOVAL

### Electrically Operated Distributors

**Note:** The entire inner spout assembly can be removed through either of the bolted end panels. Move the inner spout to the center of the distributor so the chain connection block is located at the small bolted access door (See detail, Page 8). If you have an even number of ducts you will have to move the spout by manually engaging the drive or release the reducer clutch. (See instructions for these procedures on page 9 and in the *EDI Control Installation manual*.)

#### WARNING

Turn off and lock out power to the distributor motor to prevent anyone from operating the unit while you are servicing it.

1. Remove the bolted end panels on both ends of the distributor.
2. Remove any cross bracing (used on larger distributors) on the end that you will be using to take the spout out through.
3. Take the tension off of the chain by loosening the bolts on the cross shaft bearings. These are the 1" shaft bearings located in the upper corners of the side panel.
4. Separate the chain from the inner spout by removing the (2) flat head bolts in the spout attachment bracket as shown on Page 8.
5. Unbolt the sensor pad assembly from the welded bracket on the inner spout.
6. Swing the inner spout to the last duct away from the side that you want to pull the spout out through. This will need to be done manually by climbing inside and pushing the spout. The bottom of the spout needs to be supported so that it does not swing toward center.
7. Support the top of the spout so that it does not fall when bolts holding it are removed. Remove the nuts of the top support washers.
8. The spout should then incline down toward the opening you wish to remove it through. Now simply pull out the spout.

To reinstall the spout, reverse the above steps noting the following two instructions.

1. The holes in the top plate are oversized to allow adjustment of the inner spout. Make sure the spout swings freely from end to end and parallel with the sides before tightening the nuts on the top support washers
2. Re-connect electrical power and reset the controller. Double check for proper alignment of the spout at the outlet duct and adjust if necessary (see the EDI operation manual if this is necessary).

## REMOVAL OF INNER FLEX ONLY

### Electrically Operated Distributors

#### WARNING

Turn off and lock out power to the distributor motor to prevent anyone from operating the unit while you are servicing it.

1. While supporting the flex from inside so it does not fall, reach in the hole in the flex rod access hole with a pliers and pull out the long flex pivot rod.
2. Remove flex.
3. Repeat for other flex if necessary.

#### DANGER

Be sure to use appropriate safety device to protect from falling into distributor outlets. Falling into outlets may cause injury or death.

## SECTION 2 - ASSEMBLY AND INSTALLATION

### SWINGSET DISTRIBUTOR - PARTS LIST

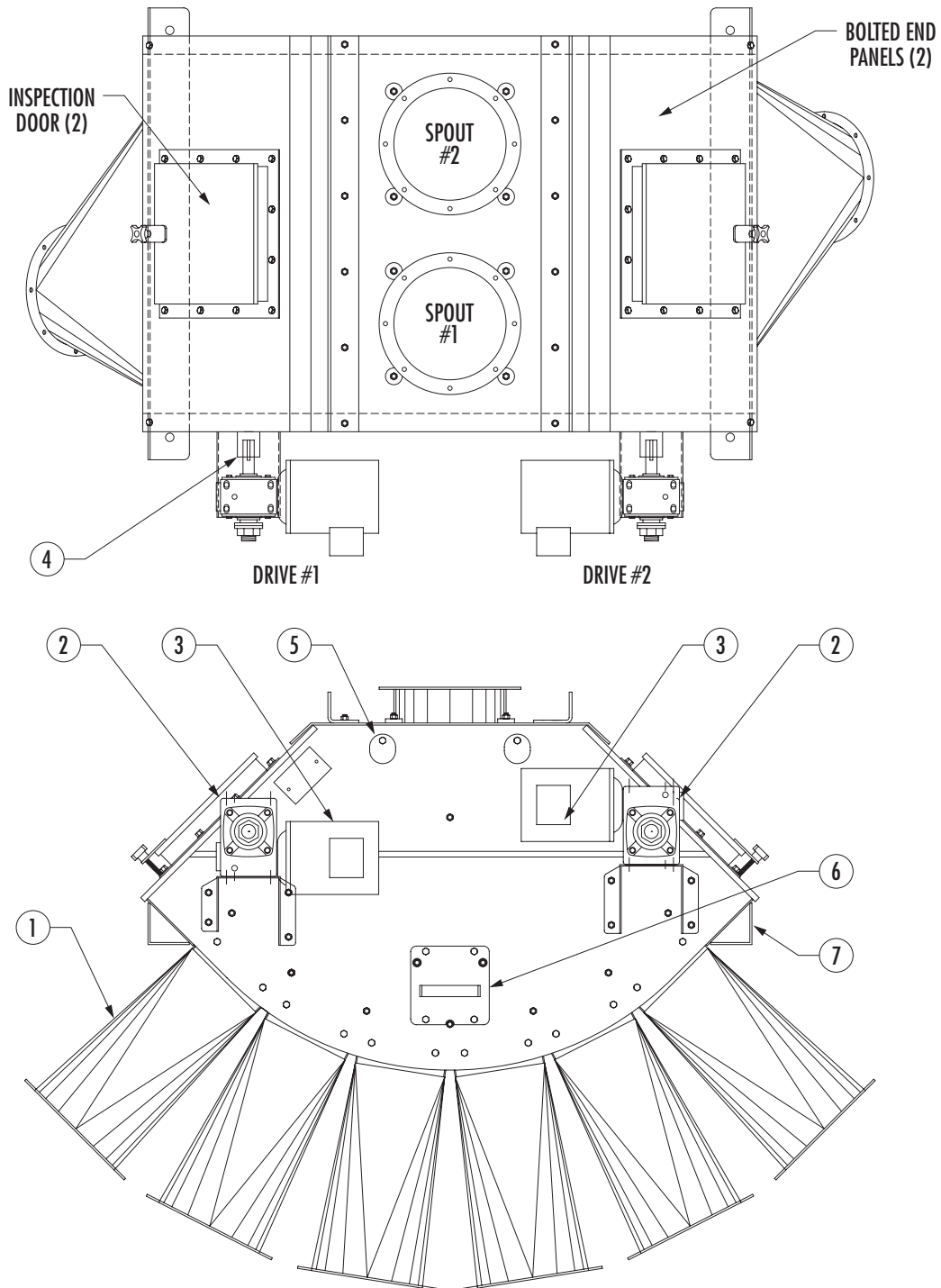

| ITEM # | DESCRIPTION          |
|--------|----------------------|
| 1.     | OUTLET DUCT          |
| 2.     | HAMPTON GEAR REDUCER |
| 3.     | MOTOR                |
| 4.     | SHAFT COUPLING       |

| ITEM # | DESCRIPTION          |
|--------|----------------------|
| 5.     | FLEX ROD COVER PLATE |
| 6.     | ACCESS DOOR          |
| 7.     | SUPPORT ANGLE        |

SWINGSET DISTRIBUTOR - PARTS LIST

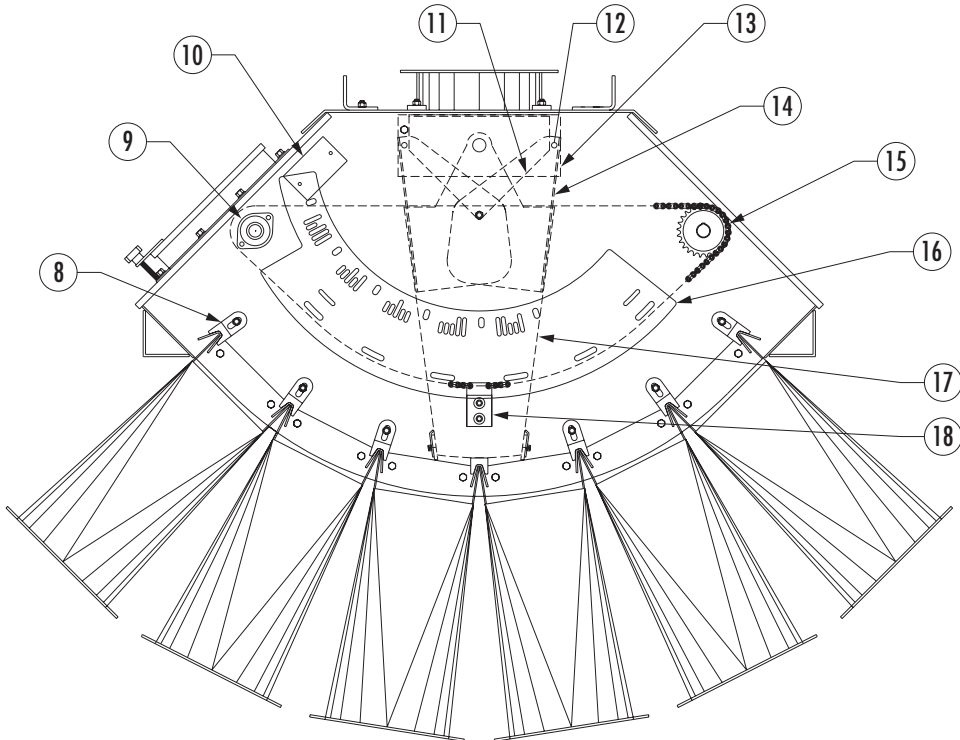
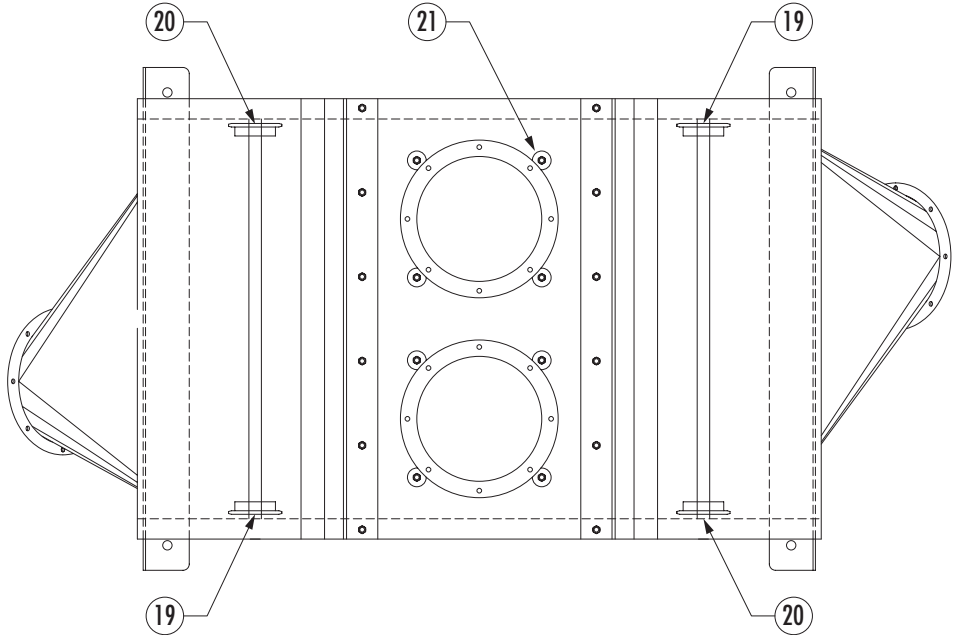

| ITEM # | DESCRIPTION           |
|--------|-----------------------|
| 8.     | DUCT CLIP             |
| 9.     | 2-BOLT FLANGE BEARING |
| 10.    | SENSOR CONNECTION BOX |
| 11.    | INNER SHIELD          |
| 12.    | FLEX ROD              |

| ITEM # | DESCRIPTION                 |
|--------|-----------------------------|
| 13.    | HANGER                      |
| 14.    | FLEX (2 REQUIRED PER SPOUT) |
| 15.    | ROLLER CHAIN                |
| 16.    | CODE BAR                    |
| 17.    | INNER SPOUT                 |

| ITEM # | DESCRIPTION              |
|--------|--------------------------|
| 18.    | CHAIN BLOCK              |
| 19.    | SPROCKET (KEYED)         |
| 20.    | SPROCKET (BRONZE BUSHED) |
| 21.    | TOP SUPPORT WASHERS      |

SECTION 2 - ASSEMBLY AND INSTALLATION

SWINGSET - SPOUT DETAIL

EXPLODED VIEW

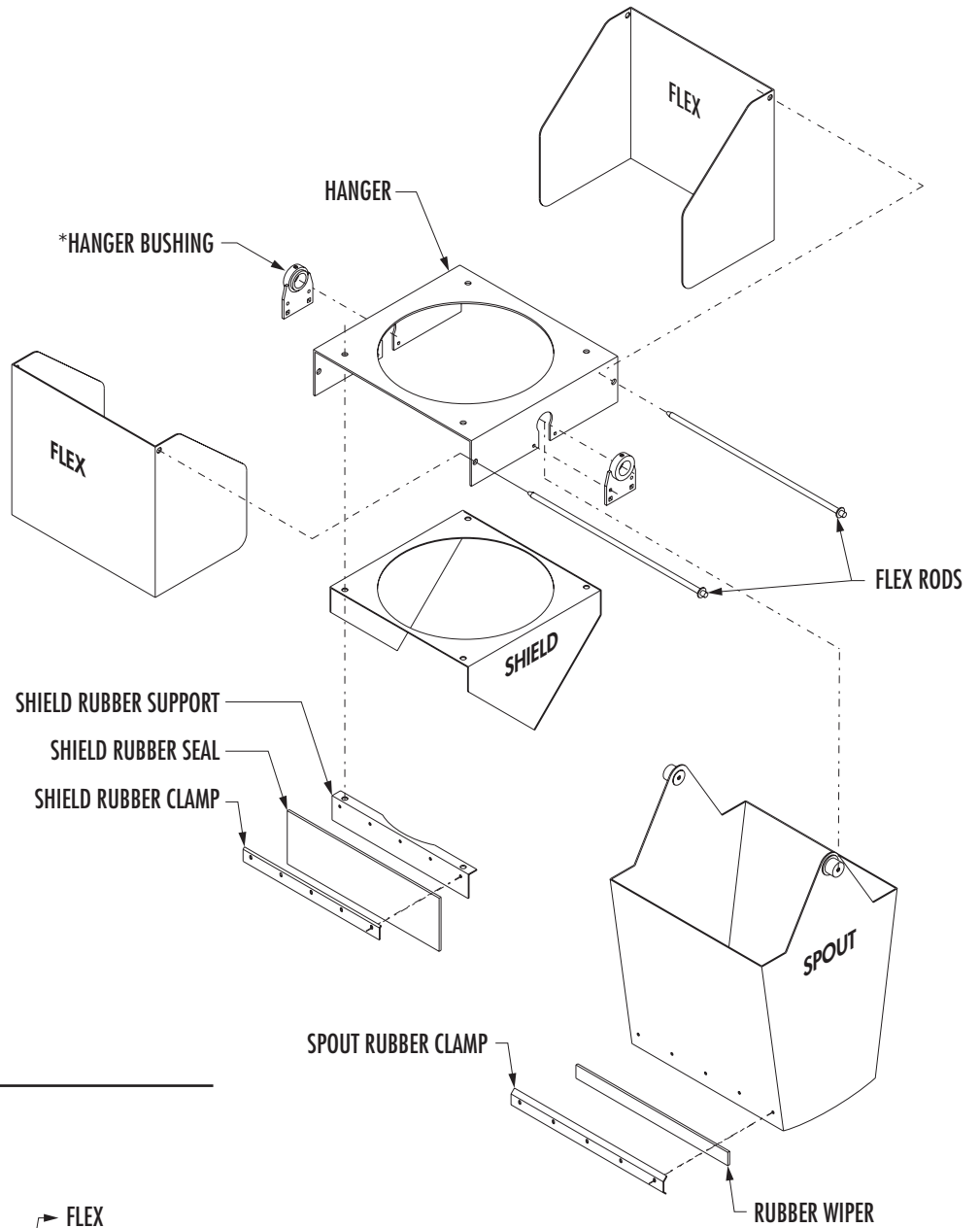

ASSEMBLED VIEW

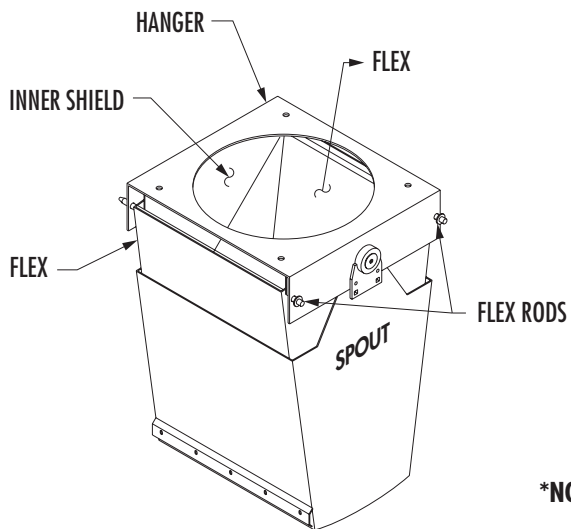

**\*NOTE:** THE HANGER BUSHING IS NOT INCLUDED ON ALL MODELS.



SWINGSET DISTRIBUTOR - DETAILS & PARTS LIST

SENSOR ASSEMBLY DETAIL

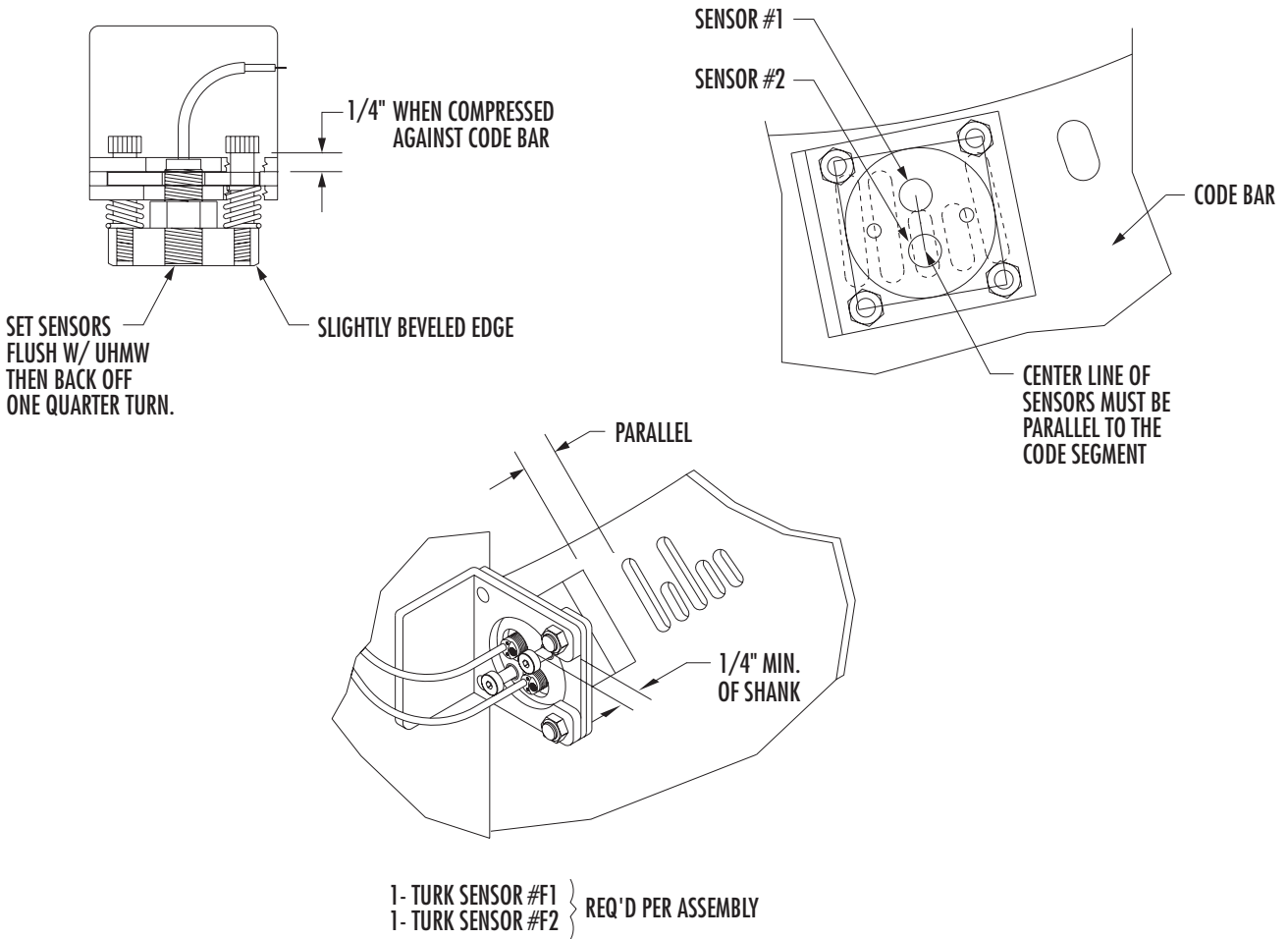

CHAIN ATTACHMENT BRACKET DETAIL

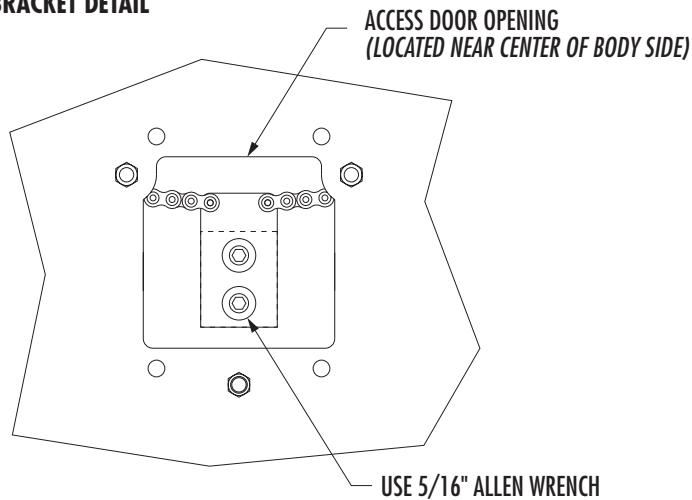

**HAMPTON GEAR REDUCER**

**Hampton Worm Gear Reducer 100:1 Ratio, 56C Frame**

This reducer is equipped with a built-in slip clutch. In the event of a mechanical blockage of the inner spout, the motor will keep running without damaging the drive train. The slip clutch is factory set at 20–45 ft/lbs. In the event the slip clutch needs to be field adjusted, loosen the set screw (using a 3 mm allen wrench) and turn the nut as shown using a torque wrench to the desired setting.

In an emergency situation where the electric control is not working, the distributor spout can be moved manually by releasing all tension on the clutch.

The reducer is filled with Mobil Delvac synthetic lubricant 75W-90 98HL97. This provides good service in most normal temperature ranges. As with any gear reducer, the oil should be changed in your normal routine maintenance schedule.

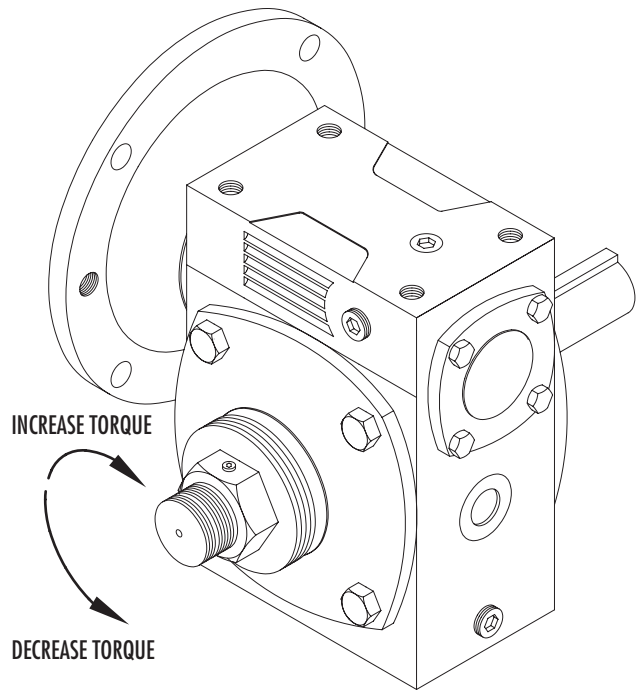

**OPERATION AND SET UP**

1. This Distributor Installation and Operation Manual is intended to deal only with the mechanical portions of your distributor.

**Included inside the control box of every distributor is the following:**

- 1- EDI Control Installation Manual
- 1- Distributor Installation & Operation Manual

The EDI Control Installation Manual should provide all the information necessary to completely set up of the electrical control system. If you have any questions regarding setup, programming, or trouble shooting; make sure you have reviewed all this information. If your problem is not addressed in either of these manuals, or you can not find a solution to your problem, contact the factory for assistance.

**MAINTENANCE**

**⚠ WARNING ⚠**  
Turn off and lock out power to the distributor motor to prevent anyone from operating the unit while you are servicing it.

1. Under normal operating conditions the SwingSet Electric Distributor will need very little maintenance. It is recommended that the oil in the gear reducer be changed regularly. See the Hampton gear reducer information at the top of this page.

**⚠ WARNING ⚠**  
Rotating spout can cause severe injury. Lock out power before opening door.

Otherwise a periodic check of the inner spout and other wear areas to make sure nothing is worn out should be the only regular attention required.

## TROUBLE SHOOTING

The Schlagel SwingSet distributor has been designed to give you many years of trouble free service with regular maintenance. Listed below are a couple of situations that may arise and the remedy.

Sensor block freeze down may rarely occur due to a combination of environmental factors, dust, moisture, and extreme cold temperature. Excessive dust may accumulate on the code bar if venting and /or dust control is inadequate. In addition high levels of moisture may be present due to the environment or material processing. To help prevent freeze down a positive pressure fan can be installed. We offer a fan with transition and elbow for mounting to the exterior of the SwingSet distributor. This fan will create a positive pressure that will eliminate most of the dust and moisture rising through the spouts. This in turn will help prevent sensor block freeze down and dust build up. The fan is available with either a single phase or three phase explosion proof motor.

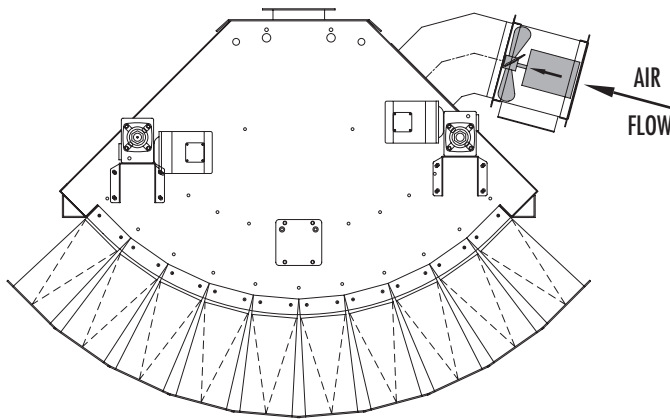

SWINGSET DISTRIBUTOR SHOWN WITH POSITIVE PRESSURE FAN

If there is a positive pressure fan installed on your SwingSet distributor and you are experiencing sensor block freeze down; make sure the fan is operating trouble free and that it is blowing air into the distributor. See detail above.

The EDI Control systems should be virtually problem free. However, situations may arise due to power shortage or a power spike. After such an event takes place, the EDI control panel may need to be reconfigured. This can be easily done using the EDI Operation manual. That was provided when the unit was purchased. If you cannot set up the control panel using the manual call the factory for assistance.



**Please contact our service department for help with any concerns or questions about your SwingSet EDI Distributor.**

**SCHLAGEL**

491 North Emerson Street • Cambridge MN 55008-1316 U.S.A.  
Toll Free (800) 328-8002      FAX (763) 689-5310  
Local / International (763) 689-5991    EMAIL [sales@schlagel.com](mailto:sales@schlagel.com)  
**[www.schlagel.com](http://www.schlagel.com)**